

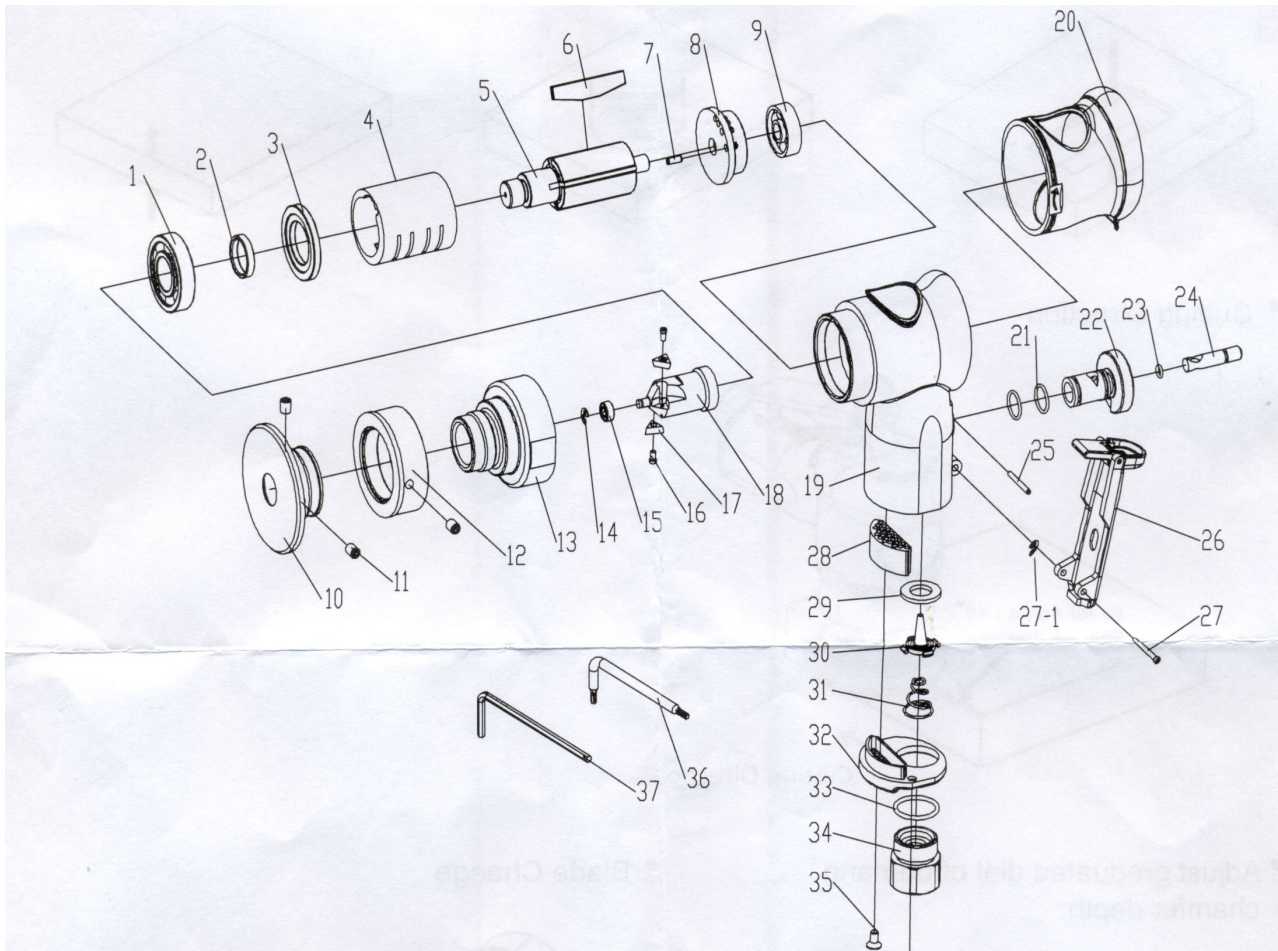

RESERVEDELISOVERSIGT – VARENR. 75175

2.



Index No.	Description	Quantity	Index No.	Description	Quantity	Index No.	Description	Quantity
01	Ball Bearing	1	14	Retainer Ring	1	27	Pin	1
02	Washer	1	15	Ball Bearing	1	27-1	Retainer Ring	1
03	Front End Plate	1	16	Screw	2	28	Exhaust muffler.	1
04	Cylinder	1	17	Triangular Blade	2	29	PU Washer	1
05	Rotor	1	18	Arbor. Shaft	1	30	Air Inlet Shaft	1
06	Rotor Blade	4	19	Housing	1	31	Valve Spring	1
07	Spring Pin	1	20	Speed Shaft	1	32	Row Spirit Cover	1
08	Rear End Plate	1	21	O-Ring	2	33	O-Ring	1
09	Ball Bearing	1	22	Sgeed Shaft	1	34	Air Inlet	1
10	Datum Seat	1	23	Q-Ring	1	35	Screw	1
11	Screw	3	24	Air Adjustment Shaft	1	36	L-Type Wrench	2
12	Scale Ring	1	25	Spring pin	1	37	Hex Key	1
13	Connect Nut	1	26	Trigger Set	1			

*Due to our continuous improvement, all specifications are subject to change without prior notice.

- Dimensions available for beveling

Depth (blind hole):
minimum 7.5mm

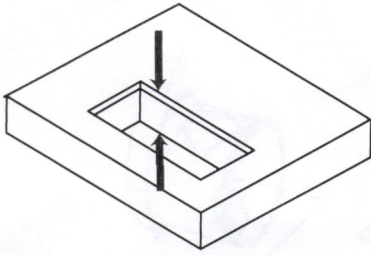

Hole Dia:
minimum 7mm

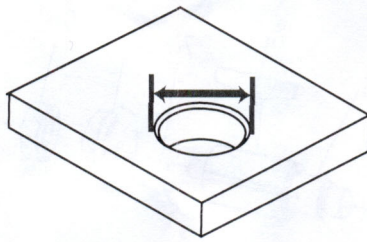

Thickness:
minimum 2.5mm

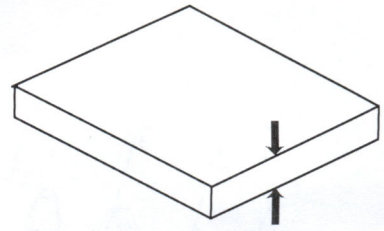

- Cutting Direction

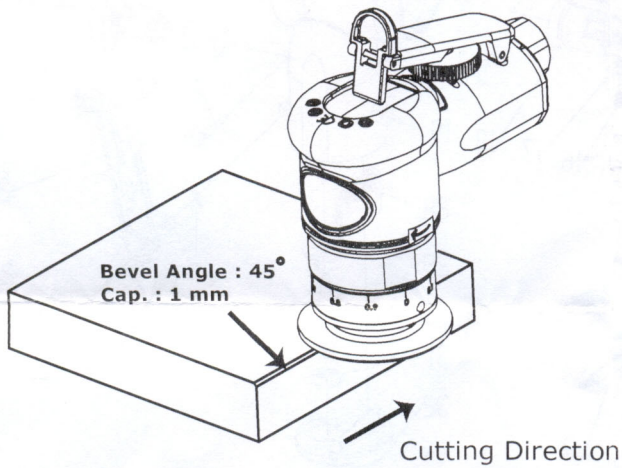

- Adjust graduated dial of demand chamfer depth

Loosen the screws (2pc) in the slot for chamfer depth adjustment

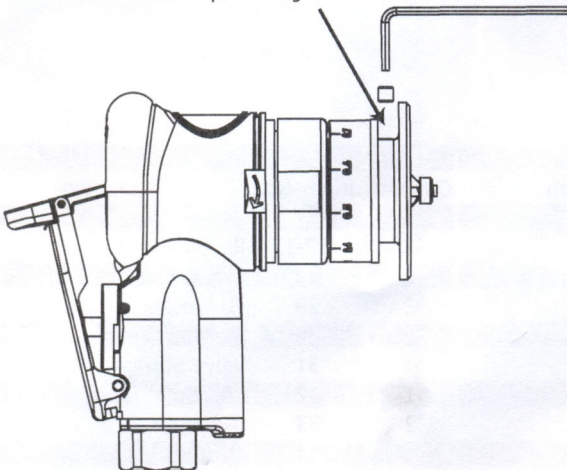

- Blade Change

