

100° 5" HEAVY DUTY GRINDER

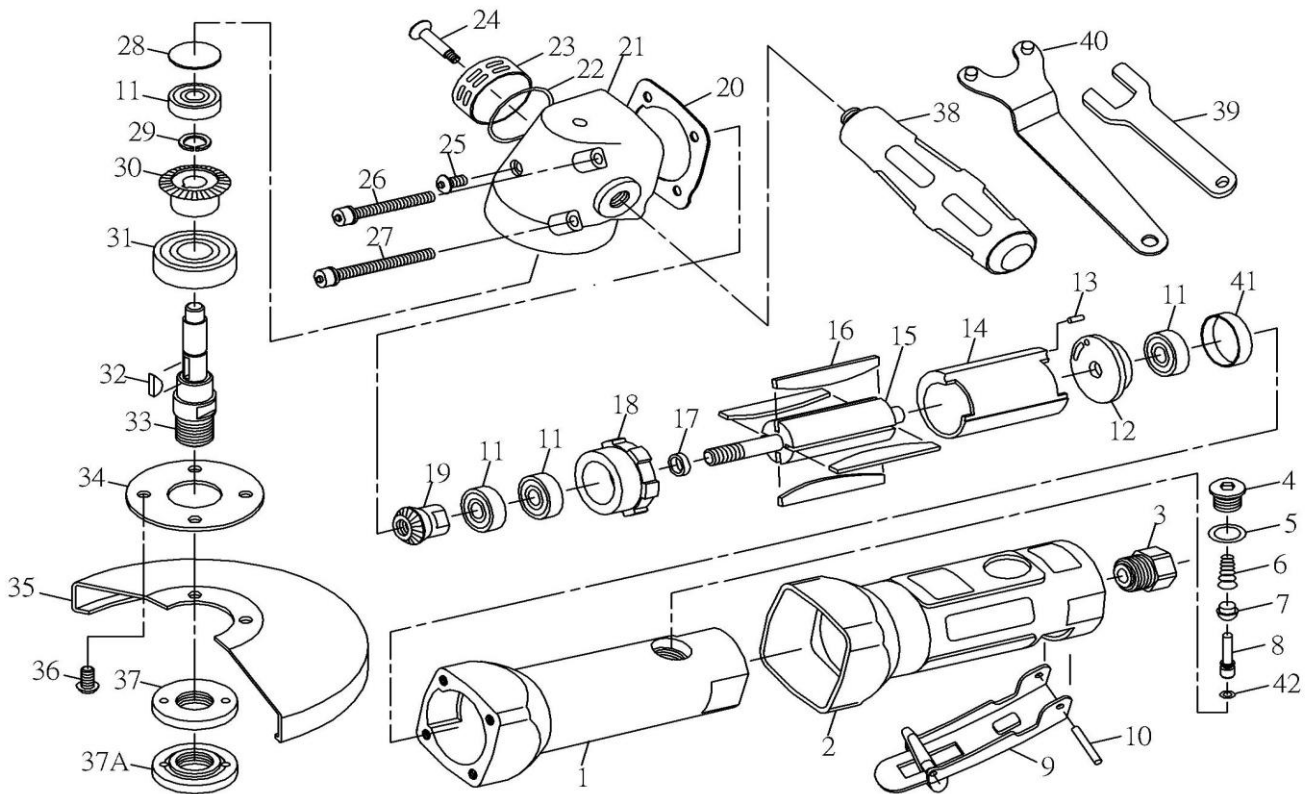

NO	PARTS NO	DESCRIPTION	QTY
01	ST80501	HOUSING	1
02	80502	RUBBER	1
03	70426	AIR INLET	1
04	70427	SCREW	1
05	50331	O-RING	1
06	50332	SPRING	1
07	70429	VALVE STEM BUSHING	1
08	80510	VALVE STEM	1
09	ST80509	LEVER	1
10	70432BK	PIN	1
11	21024	BEARING	4
12	ST70424	REAR PLATE	1
13	70423	PIN(STEEL BALL)	1
14	ST80517	CYLINDER	1
15	80518	ROTOR	1
16	80519	ROTOR BLADE	4
17	20022	BEARING SPACER	1
18	ST70418	FRONT PLATE	1
19	80517	BEVEL GEAR	1
20	80523	PACKING	1
21	ST80524A	ANGLE HOUSING	1
22	70011	O-RING	1

NO	PARTS NO	DESCRIPTION	QTY
23	STAGD100-22	EXHAUST SLEEVE	1
24	AGD100-23	SCREW	1
25	80528	SCREW(M5*6)	1
26	70415-2	SCREW(M5*45L)	2
27	AGD100-26	SCREW(M5*55L)	2
28	70412-1	SPACER	1
29	70410	RETAINING RING	1
30	80529	BEVEL GEAR	1
31	ST87036A	BEARING (6202ZZ)	1
32	ST70407	KEY	1
33	80536,3	SHAFT (5/8")	1
34	ST80537-3	FACE PLATE	1
35	ST80537	DISC COVER (5")	1
36	ST70403A	SCREW	4
37	ST85562A	DISC NUT (5/8")	1
37A	ST85563A	DISC NUT (5/8")	1
38	BT80438-12.5	HANDLE	1
39	BT21038-14	STOP SPANNER (14M/M)	1
40	BT87057	DISC SPANNER	1
41	80441	SHROUD	1
42	OB-04	O-RING	1

WE RESERVE THE RIGHT FOR ANY DESIGNING CHANGES TO THE PARTS AND WITHOUT ANY NOTICEMENT IN ADVANCE.

